

SISTEME DE FILTRARE HELIX AUTOMATIC

- SERIA 200 -

Domeniu de aplicare

Filtrele automate asigura filtrarea eficienta a apelor de suprafata cu continut ridicat de suspensii.

Sistemele de filtrare HELIX ofera solutia perfecta intr-o multitudine de aplicatii, unde este necesara filtrarea mecanica continua a apei in cele mai diverse domenii (apa de racire, ind. metalurgica, ind. chimica, ind. alimentara, tratarea si filtrarea apei).

Avantaje

- functionare complet automata;
- finete de filtrare predefinita;
- capacitate mare de filtrare;
- fiabilitate mare cu intretinere usoara;
- operare usoara si simpla;
- volum mic de apa necesar la spalarea inversa.

Caracteristici constructive

- debit max. 256 m³/h;
- nr. unitati filtrare 2 - 6;
- suprafata de filtrare max. 8,952 cm²;
- dimensiune IN/OUT 3"- 6";
- conducte principale HDPE;
- configuratie standard (water pilot); optional (air pilot);
- tensiune controler 220Vca / 24 Vcc.

CARACTERISTICI FILTRARE / Unitate de filtrare

Calitate apa bruta	Finete filtrare					
	micron mesh	200 75	130 120	100 150	50	20
BUNA	mc/h	23	17	9		
MEDIE	mc/h	20	14	7		
PROASTA	mc/h	18	10	5		
FOARTE PROASTA	mc/h	12	7	3		

CARACTERISTICI SPALARE INVERSA

	200 µm 130 µm	100 µm	50 µm 20 µm
Presiune minima de spalare / filtru	2.8 bari	3.5 bari	4 bari
Debit minim de spalare / filtru	2.5 l/s	3.1 l/s	3.3 l/s



SISTEME DE FILTRARE HELIX AUTOMATIC - SERIA 200 -

Componenta

1. Corp filtru
2. Cartus filtrant tip pachet de discuri
3. Valve automate hidropneumatice

4. Conducta magistrala de intrare
5. Conducta magistrala de iesire
6. Conducta de drenaj

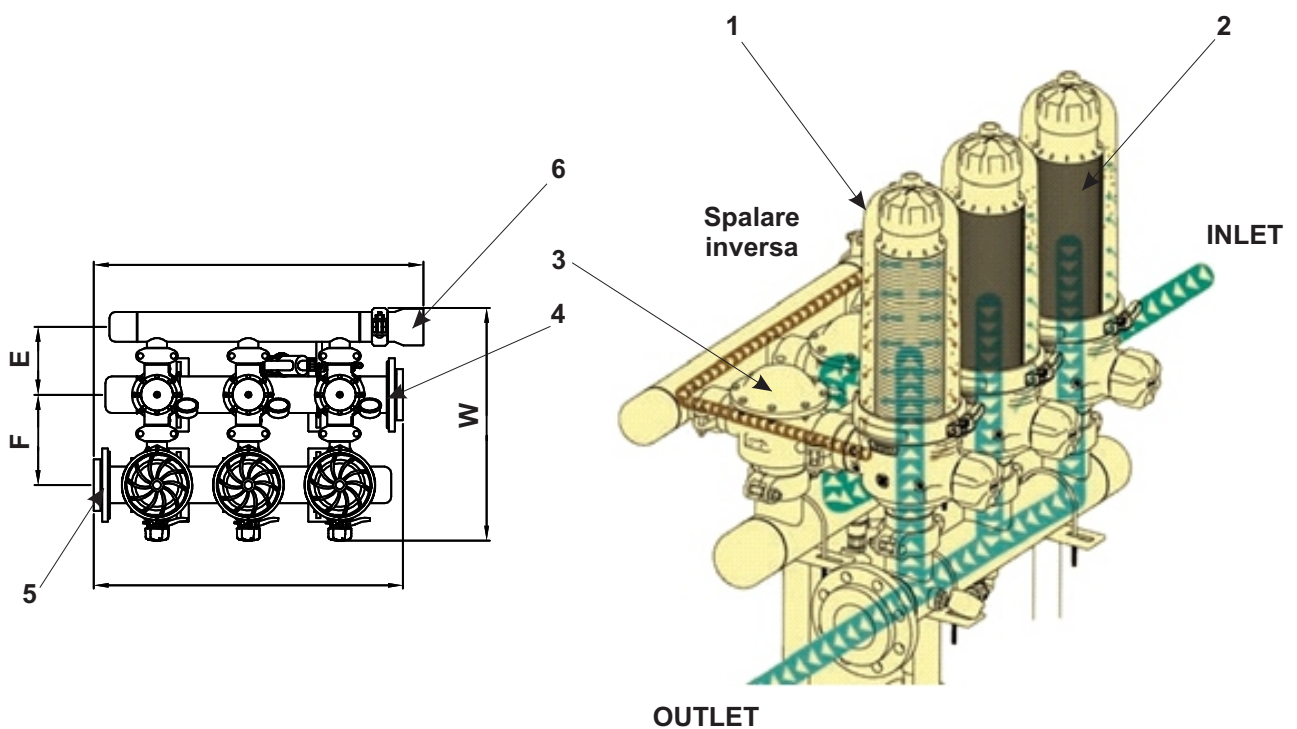
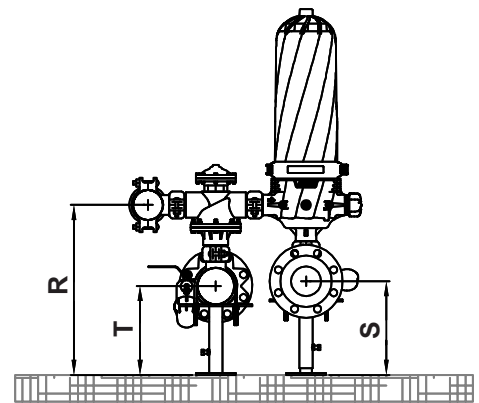
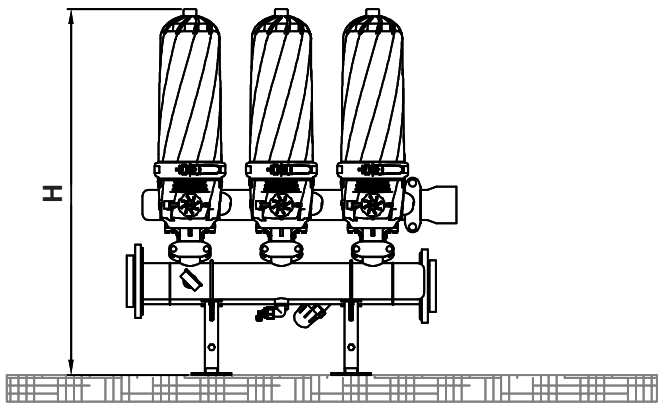

Caracteristici tehnice

Model	Construcție		
	Nr. filtre	Dimensiune conducta principala	Suprafata filtrare [cm ²]
202/4FX	2 x 2"	4" – DN100	2,984
203/4FX	3 x 2"	4" – DN100	4,476
204/6FX	4 x 2"	6" – DN150	5,968
205/6FX	5 x 2"	6" – DN150	7,460
206/6FX	6 x 2"	6" – DN150	8,952

Model	Dimensiuni [mm]								
	F	E	D	L	W	R	T	S	H
202/4FX	272	204	615	700	694	511	267	281	1100
203/4FX	272	204	830	945	694	511	267	281	1100
204/6FX	272	204	1145	1267	694	561	292	306	1150
205/6FX	272	204	1420	1542	694	561	292	306	1150
206/6FX	272	204	1695	1817	694	561	292	306	1150